

OPERATION MANUAL



TITAN TABLE TOP

Table Of Content

1. Introduction	1
1.1 Titan Table Top Features	1
1.2 Specification	1
1.3 Connections	1
1.3.1 RS232	1
1.3.2 Power supply	2
1.4 Physical Dimensions	2
1.5 Display and Key Descriptions	3
1.5.1 Display	3
1.5.2 Keypad	3
1.5.3 Keys and Key Press Description	4
1.5.4 Two Keys Functions	4
2. User Setting	4
2.1 Display Speed	4
2.2 Zero Tracking	5
2.3 Zero Lock	5
2.4 Power On Zero	5
2.5 Auto Sleep Time	6
2.6 Liter Factor	6
2.7 Stability	7
2.8 Sensitivity	7
2.9 Accumulation	7
2.10 Display Intensity	8
2.11 Backlit Intensity	8
3. System Setting	8
3.1 Serial Number	8
3.2 Factory Reset	8
4. Communication Setting	9
4.1 RS232	9
4.1.1 Baud Rate	9
4.1.2 Data Bits	9
4.1.3 Stop Bit	9
4.1.4 Parity	9
4.1.5 Data Out	9
4.1.6 Transmission mode	10
4.1.6.1 Continuous transmission	10

4.1.6.2 Print	10
4.1.6.3 Once After Stable	10
4.1.6.4 Only Once After Stable	10
4.1.6.5 Command	10
4.1.6.6 OFF	10
4.1.7 String Direction	10
4.1.8 Decimal Point Transmit	11
4.1.9 Transmit Sign	11
4.1.10 Leading Zero	11
4.1.11 Unit	11
4.1.12 Line Feed	12
5. Printer Setting	12
5.1 Set Printer	12
5.2 Set Header	12
5.2.1 Header Line 1	12
5.2.1.1 Font Style	13
5.2.1.2 Character	13
5.2.1.3 Location	13
5.2.1.4 Scroll Line	14
5.2.2 Header Line 2	14
5.2.3 Header Line 3	14
5.3 Footer Settings	14
5.3.1 Footer Line 1	14
5.3.1.1 Font Style	14
5.3.1.2 Character	15
5.3.1.3 Location	15
5.3.1.4 Scroll Line 1	15
5.3.2 Footer Line 2	16
5.3.3 Footer Line 3	16
5.4 Separation Line	16
5.5 Copy	16
5.6 Auto Print	16
5.7 Print Format	17
5.8 Printer Permissions	18
6 Factory Settings	19
6.1 Scale Settings	19
6.1.1 Snr	19
6.1.2 Sdt	19

6.1.3 Pdt	19
6.1.4 rdt:- 38	19
6.1.5 Range	19
6.1.5.1 SR-Single Range	19
6.1.5.2 DR-Dual Range	19
6.1.5.3 TR-Triple Range	20
6.1.6 Capacity	20
6.1.7 Division	20
6.1.8 Decimal Point	20
6.1.9 Unit	20
6.2 Factory Calibration	21
6.3 Standard Calibration	21
7 Error Table	21
8 Modes	22
8.1 Simple Weighing	22
8.2 Simple Counting	22
8.3 Accumulation	22
8.4 Litre Conversion	23



EAGLE Service

We ensure we will provide essential services for dependable performance of the Titan Table Top. Congratulations on choosing the quality and precision of EAGLE. Proper use of your new equipment according to this manual and regular calibration and maintenance by our factory trained service team ensures dependable and accurate operation, protecting your investment. Contact us about a service agreement tailored to your needs and budget. There are several important ways to ensure you maximize the performance of your investment:

1. Contact EAGLE for service: The value of a measurement is proportional to its accuracy – an out of specification scale can diminish quality, reduce profits and increase liability. Timely service from EAGLE will ensure accuracy and optimize uptime and equipment life.

A. Installation, Configuration, Integration and Training: Our service representatives are factory trained, weighing equipment experts. We make certain that your weighing equipment is ready for production in a cost effective and timely fashion and those personnel are trained for success.

B. Initial Calibration Documentation: The installation environment and application requirements are unique for every industrial Terminal so performance must be tested and certified. Our calibration services and certificates document accuracy to ensure production quality and provide a quality system record of performance.

C. Periodic Calibration Maintenance: A calibration service agreement provides ongoing confidence in your weighing process and documentation of compliance with requirements. We offer a variety of service plans that are scheduled to meet your needs and designed to fit your budget.

© **EAGLE 2023**

No part of this manual may be reproduced or transmitted in any form or by any means, electronic or mechanical, including photocopying and recording, for any purpose without the express written permission of EAGLE.

This documentation is furnished with Restricted Rights.

Copyright 2023 EAGLE. This documentation contains proprietary information of EAGLE. It may not be copied in whole or in part without the express written consent of EAGLE.

EAGLE reserves the right to make refinements or changes to the product or manual without notice.

COPYRIGHT

EAGLE ® is a registered trademark of E.G.KANTAWALLA PVT. LTD. all other brand or product names are trademarks or registered trademarks of their respective companies.

EAGLE RESERVES THE RIGHT TO MAKE REFINEMENTS OR CHANGES WITHOUT NOTICE.

Statement regarding harmful substances.

We do not make direct use of harmful materials such as asbestos, radioactive substances or arsenic compounds. However, we purchase components from third party suppliers, which may contain some of these substances in very small quantities.

WARNINGS AND CAUTIONS



CAUTION! Read this manual before operating or servicing this terminal. Follow these instructions carefully. Do not allow untrained personnel to operate, clean, inspect, maintain, service, or tamper with this terminal. Always disconnect this equipment from the power source before cleaning or performing maintenance. Call eagle for parts, information, and service.



WARNING! Only permit qualified personnel to service this terminal. Exercise care when making checks, tests and adjustments that must be made with power on. Failing to observe these precautions can result in bodily harm.



Warning! For continued protection against shock hazard connect to properly grounded outlet only. Do not remove the ground prong.

Warning! Disconnect all power to this unit before removing any connection, opening the enclosure or servicing.



Warning! Before connecting/disconnecting any internal electronic components or interconnecting wiring between electronic terminal always remove power and wait at least thirty (30) seconds before any connections or disconnections are made. Failure to observe these precautions could result in damage to or destruction of the terminal or bodily harm.



Disposal of Electrical and Electronic Equipment

In conformance with the European Directive 2002/96/EC on Waste Electrical and Electronic Equipment (WEEE) this device may not be disposed of in domestic waste. This also applies to countries outside the EU, per their specific requirements.

Please dispose of this product in accordance with local regulations at the collecting point specified for electrical and electronic equipment.

If you have any questions, please contact the responsible authority or the distributor from which you purchased this device. Should this device be passed on to other parties (for private or professional use), the content of this regulation must also be related.

Thank you for your contribution to environmental protection.

1. Introduction

1.1 Titan Table top Features

- 1) Light and Compact Table Top Weighing Scale
- 2) ABS Cabinet
- 3) SS 304 Pan
- 4) Level adjustable legs
- 5) Spirit level indicator near the pan
- 6) Lithium Ion battery operated
- 7) RS232 Port
- 8) C type USB charging power adapter
- 9) Rear Display
- 10) Available in LED and LCD variants
- 11) LCD Variant with orange display
- 12) Weighing, Piece Counting, Accumulation, Litre conversion modes
- 13) Provision to connect with portable thermal printer

1.2 Specifications

Pan Size - 250x195 mm
Display Size (LCD version) - 128 x 32 mm
Display Size (LED Version) - 25 mm digit height
Display Colour (LCD Version) - Orange
Display Colour (LED Version) - Green
Battery - 7.4 V 1200 mA
Adapter - 5 V 1 A USB C type

1.3 Connections

1.3.1 RS232

RS 232 serial connection is done with three wire as indicated below

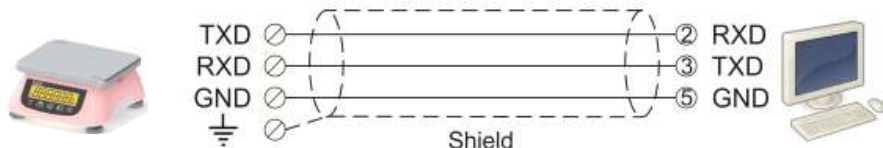

Rs232 serial interface connections

1.3.2 Power supply

The quality of the instrument's ground will determine the accuracy and the safety of your measuring system. A proper ground connection is needed to minimize extraneous electrical noise affects on the measurement. A poor ground can result in an unsafe and unstable operation. It is important that the instrument should not share power lines with noise-generating parts such as heavy load switching relays, motor control equipment, inductive loads, etc. If the condition of the power line in the plant is poor, prepare a special power line and grounding. The pin configuration of the 5v 1 A power supply© type) connector located at back side off the indicator below the rear display is shown in Figure below. Be sure, the power supply is switched of before connection.



The pin layout of the 5V 1 A, USB C type connector of Titan Table Top weighing Scale.

1.4 Physical Dimensions

Please refer below figure (1) for dimension of Titan Table Top weighing scale

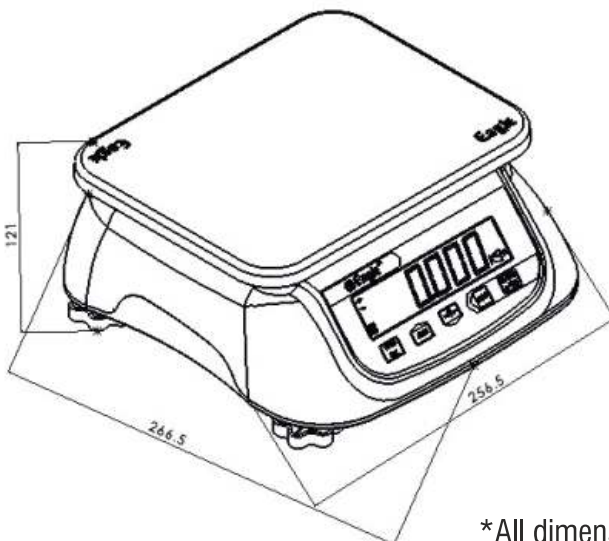

*All dimensions in mm

1.5 Display and Key Descriptions

1.5.1 Display

The weight display of Titan Table top weighing scale comes with two variants- LED variant and LCD variant. The display is having the following indications

Gross - Indicates the displayed weight is gross weight.

Net - Indicates the displayed weight is net weight.

→0← - Indicates the scale counts are in zero condition.

~ - Indicates the weight value on the display is unstable.

Σ - Indicates the accumulation mode is enabled.

 - Battery symbol.

 - Indicates the piece count mode.



1.5.2 Keypad

The keys and the key functions of Titan are:



Titan Keypad image

1.5.3 Keys and Key Press Description

Keys	Func/Esc	Zero	Tare	N/G	M+ /MR
Short press from home screen	To enter into counting mode	To make the display zero	To tare the weight kept on the platform	To toggle between Net and Gross if tare is used	Print and accumulate
Long Press from home screen	To enter into parameter settings	To show the firmware version number	-	-	ON/OFF
Short press when inside the settings	To go to previous step	Increment	Decrement	Shift (Right to Left)	Enter
Long press during ON (Count Down)	To enter into factory settings	-	-	-	-

1.5.4 Two Keys Pressing Together Functions:

1) Func/Esc + M+ /MR - Show the no. of times & total accumulated weight (This will work when the Accumulation mode in ON)

2) Func/Esc + Zero - Clear accumulation memory if the home screen is in zero condition. (including weight and accumulated times) and also to end the accumulation print (print format 3). (This will work when the Accumulation mode in ON)

*Accumulation Function works based on the USER SETTINGS-ACCUMULATION

2. User Setting (uSEr)

Long press 'F' key and the display will show 'uSEr' and press enter key to go inside the user settings. Zero key and Tare key are used for increment and decrement or for scrolling up and down between the sub menus.

2.1 Display Speed (SPd):-

When ENTER key is pressed from SPd , the display will show 'SPd 2'. Default value is 2.

This is used to vary the display speed.

1 is the fastest and 5 for slowest.

Once the speed is chosen between 1 to 5, press 'ENTER' button to select, and after selection the

2.2 Zero Tracking (Ztrc):-

When ENTER key is pressed from Ztrc, the display will show 'Ztrc02'.

Default value is 02.

User can set the zero tracking value between 00 to 99 based on the site/environment conditions.

For example if we enter 05 here and the scale least count/division is 2 g, then $2\text{ g} \times 5 = 10\text{ g}$, so up to 10 g display will track the values to zero.

2.3 Zero Lock (ZLoC):-

When ENTER key is pressed from ZLoc, the display will show 'ZLoC02'.

Default value is 02

User can set the zero lock value between 00 to 99 based on the site/environment conditions.

For example if we enter 05 here and the scale least count/division is 2 g, then $2\text{ g} \times 5 = 10\text{ g}$, so up to 10 g display will show only zero and when we add the weights more than 10 g, then it will show the actual value kept on the scale.

2.4 Power On Zero (PZro) :-

When ENTER key is pressed from PZro, the display will show 'PZro y'.

Default value is 02.

- y- Power On Zero function ON.
- n- Power On Zero function OFF.

When POWER ON ZERO is ON, and when we power OFF and ON the scale, the display will show Zero, irrespective of weight on the platform which is $< 20\%$ of full scale.

(This function is temporarily removed from the parameter list in the scale)

If the weight on the platform is more than 20% of the full scale then the display will show Err20 and the scale will produce a beep sound.

If the display shows Err20, then the scale should be checked and remove the extra weights placed on the platform and ensure the platform is clear and then Power OFF and Power on the scale

*Err 20 is not applicable for negative values

2.5 Auto Sleep Time (ASLP):-

When ENTER key is pressed from ASLP, the display will show 'ASLP05'. Default value is 05.

We can set Auto sleep time from 01 to 99 seconds.

e.g. If we select 5 seconds, then if the scale display values is in zero for 5 seconds, the scale will go into sleep mode. During sleep mode, LCD backlight will off if it is LCD Variant.

2.6 Liter Factor (LF):-

When ENTER key is pressed from LF, the display will show the default value 0.970 which is the litre conversion value of Milk.

Customer can change the value as per the specific liquid's conversion factor.

Use Zero key for the increment and Tare key for the decrement and N/G key for the shift.

User can enter the LF up to 1.000.

If user want to enter the LF more than 1.000 the display will ask to enter the password "PASS" and we have to enter 1009 using zero key for increment, Tare key for decrement and N/G for shift.

2.7 Stability (Stb):-

When ENTER key is pressed from Stb , the display will show 'Stb 01' .

Default value is 05.

Stability is the time required for the weight placed on the scale to become stable.

Unstability is indicated by a sine symbol on the left side of the display in the weighing mode.

When the sine symbol is not flashing, the weight is stable. When the symbol flashes, the weight is unstable.

2.8 Sensitivity (Sen):-

When ENTER key is pressed from SEN , the display will show 'SEn' .

Default value is 05.

It can be changed based on the site environments to avoid the frequent fluctuations in the weight values.

2.9 Accumulation (ACC):-

When ENTER key is pressed from ACC , the display will show 'ACC oFF' . Default value is oFF.

Accumulation of displayed weight can be done using this function. Auto and Manual mode is there in this section.

A-Auto- Every time before adding the current stable weight to the accumulation memory it checks for the stability and the weight above threshold and second accumulation will be done only after removing the first weight and display returns to zero.

Threshold value should be entered in auto mode & above this threshold value, the auto accumulation will happen when the weight is stable.

M-Manual- Accumulation can be done using M+/MR key.

Accumulated weight value & No. of accumulated times is available to see using **Func + M+/MR key**.

Clear accumulation memory can be done using **Func + Zero key**.

2.10 Display Intensity (dSP it):-

When ENTER key is pressed from dSP it, the display the show dSP it 03.

The default value is 03.

It is advisable do not change it from its default value.

2.11 Backlit Intensity (bCL it):-

When ENTER key is pressed from bCL it, the display the show bCL it 03.

The default value is 03.

3. System Setting (SySt)

These system setting is password protected. When we press enter key from “Syst”, display will show PASS, then we have to press N/G Key (left shift) and enter 1918 using Zero Key (increment), Tare Key (decrement) and use N/G Key (to shift the previous entered to the left)

3.1 Serial Number (Sno):-

This is related to print (if we connect external RD-EK 32 S thermal printer). The serial number will be printed increment wise. Only reset option is available in this settings and when we press enter key from Sno, display will show rSET and the serial number will be reset and start from 1 in the print.

3.2 Factory Reset (FrSt):-

This is used to do the factory reset setting. After the factory reset, all the parameters will be set to its default values or functions (Except calibration settings).

When we press enter key from FrSt, the display will show FrSt y.

FrSt y - Do the factory reset

FrSt n - Do not do the factory reset

4. Communication Setting (CS)

4.1 RS232 (rS232):-

4.1.1 Baud Rate (brAt)

The following are the baud rates available - 2400, 4800, 9600, 19200, 38400,57600,115200.

Use the zero and tare keys to select the required baud rate. Once the baud rate is selected, press the “ENTER” key and it come out of the sub settings.

4.1.2 Data Bits (db):-

The following are the data bits available-7 & 8. Select as per requirement and press Enter key.

4.1.3 Stop Bit (Sb):-

The following are the data bits available-1 & 2. Select as per requirement and press Enter key.

4.1.4 Parity (Pr):-

The following are the parity available-None (n), Even (E), Odd (o). Select as per requirement and press Enter key.

4.1.5 Data Out (dout):-

Using RS232 we can send Net weight or Gross weight or Tare weight or Pieces, Litre using this settings.

When we press enter key from dout, the display will show dout g.

Gross is default value.

Use up or down arrow to toggle between g, n, t, P, L

4.1.6 Transmission mode (tr):-

4.1.6.1 Continuous transmission (Con) :-

This will transmit the weight continuous to the receiving device.

4.1.6.2 Print (Prt):-

Weight will be transmitted when we press MR/M+ key (short press)

4.1.6.3 Once After Stable (oSt):-

Weight will be transmitted (continuously) once after stable.

4.1.6.4 Only Once After Stable (oSto):-

Weight will be transmitted only once after stable

4.1.6.5 Command (Cd):-

Weight will be transmitted after the scale receives the command from the PC.

If "CD" is selected in transmission mode, then we have to enter any one character (Like "#, _, -, *") here. On receiving this character, weight should be transmitted only once.

4.1.6.6 OFF:-

If OFF is selected, the RS232 data transmission will be disabled.

4.1.7 String Direction (Strdi):-

Using the String direction we can set the RS232 string direction either in forward or in reverse

F-Forward (To transmit weight on forward direction)

R-Reverse (To transmit weight on reverse direction)

For example if we select R (Reverse) in this setting and if the weight is showing in the display is 8.532 then in RS232 the weight will be transmitted as 235.8

4.1.7 String Direction (Strdi):-

Using the String direction we can set the RS232 string direction either in forward or in reverse

F-Forward (To transmit weight on forward direction)

R-Reverse (To transmit weight on reverse direction)

For example if we select R (Reverse) in this setting and if the weight is showing in the display is 8.532 then in RS232 the weight will be transmitted as 235.8

4.1.8 Decimal Point Transmit (Str dp):-

We can select either Yes or No to transmit the decimal point along with the weight.

Y-Yes (To transmit decimal point)

N-No

If we keep N (NO), then if the weight in the display is 8.532 (considering F forward in previous settings), then in RS232 the weight will be transmitted as 8532

4.1.9 Transmit Sign (Str Sg):-

We can select either Yes or No to transmit the weight sign (positive or negative) along with the RS232 string.

Y - Yes (To transmit sign)

N-No

If we keep Y (Yes) in this setting, then if the weight in the display is 8.532, then in the RS232 it will be transmitted as +8.532

4.1.10 Leading Zero (Str LZ):-

This setting decides whether the leading zero before the weight value should be transmitted in the RS232 string or not. Use Zero & Tare Key to choose Y or N and press ENTER key.

Y - Yes (To transmit leading zero)

N-No

If we keep Y (Yes) in this setting, then if the weight in the display is 8.532, then in the RS232, it will be transmitted as 008.532 (Leading zeros will be added in prefix to the weight)

4.1.11 Unit (Str ut):-

This step decides whether scale default unit should transmit in the Rs232 string or not. Use Zero & Tare key to choose Y or N and press ENTER key.

Y - Yes (To transmit scale's unit)

N-No

4.1.12 Line Feed (LF):-

If we select Line Feed Y (Yes), then the data transferred through Rs232 will be with Line Feed and Carriage return.

For ex if the data transmitted is 2.000 kg then it will be transmitted as below,

2.000kg

2.000kg

2.000kg

If Next data line is N (No), then data transferred through RS232 will be without Line Feed and Carriage Return and it will be on same line For ex if the data transmitted is 2.000 kg then it will be transmitted as below,

2.000kg

2.000kg

2.000kg

2.000kg

5.Printer Settings (Ptr)

This setting is exclusively used to set the parameters related to the print if we connect it to RD-EK 32 S thermal label/receipt printer.

5.1 Set Printer (SPrn):-

Here we can select anyone of the printers from below list and connect the particular printer to the RS232 port of the scale.

32 R- 32 Column printer used for receipts (RD-EK 32 S)

32 L - 32 Column printers for labels (RD-EK 32 S)

40 - 40 column dot matrix printer (only for receipts)

The printer will be standalone type.

5.2 Set Header (Hdr) :-

When ENTER key is pressed from Hdr , the display will show 'Ln1 '.

Three header lines can be added (Header Line 1, Header Line 2, Header Line 3)

5.2.1 Header Line 1 (Ln1) :-

When ENTER key is pressed from Ln1 , the display will show FS (Font Style)

5.2.1.1 Font Style :-

On pressing the FS, the display will show FS b

The default font style is Bold (b).

Use Up and Down arrow to scroll between

l (Italic), u (Underline), nu (normal underline), bu (bold underline), iu (italic underline), n (normal)

Select the desired font style and and press Enter key.

5.2.1.2 Character (CHr) :-

On pressing the CHr, the display will show Hl01-

Use up and down arrow to enter the value in the Header Line 1

Location 1

HL - Header Line

01 - Location 1

There are 40 locations available to enter the values. Ie. 40 characters can be entered in Header Line 1. In each location one characters can be entered.

When we press up or down arrow, the alphThe character will be displayed hereabets/numbers/symbols will be scrolled in ascending order.

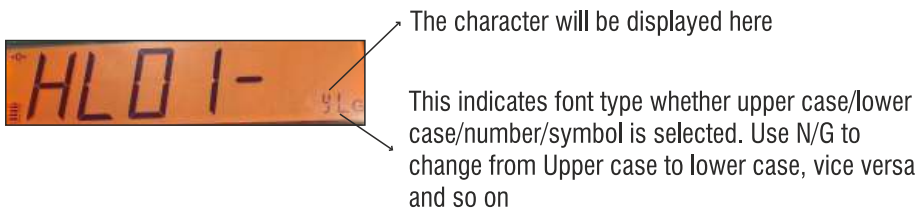

Once the font type is selected, then for the first time press UP arrow to change the values.

5.2.1.3 Location (LoC) :-

On pressing the LoC, the display will show LoC-01

Using up and down arrows we can scroll and reach the particular location where we can edit the character.

The procedure of editing the values in same which is explained in section 5.2.1.2

5.2.1.4 Scroll Line 1 (SCLn1):-

When we press enter key from this step whatever we enter for header line 1 from position HL1 will scroll from character-right to left and after a time delay it will come out to SCLn1.

5.2.2 Header Line 2 (Ln2) :-

This is similar to section 5.2.1

5.2.3 Header Line 3 (Ln3) :-

This is similar to section 5.2.1

5.3 Footer Settings

When ENTER key is pressed from Ftr , the display will show 'Ln1 '.

Three header lines can be added (Footer Line 1, Footer Line 2, Footer Line 3)

5.3.1 Footer Line 1 (Ln1) :-

When ENTER key is pressed from Ln1 , the display will show FS (Font Style)

5.3.1.1 Font Style :-

On pressing the FS, the display will show FS b The default font style is Bold (b). Use Up and Down arrow to scroll between i (Italic), u (Underline), nu (normal underline), bu (bold underline), iu (italic underline), n (normal) Select the desired font style and and press Enter key.

5.3.1.2 Character (CHr) :-

On pressing the CHr, the display will show FL01-

Use up and down arrow to enter the value in the Footer Line 1 Location 1

FL - Footer Line

01 - Location 1

There are 40 locations available to enter the values. Ie. 40 characters can be entered in Footer Line 1. In each location one characters can be entered.

When we press up or down arrow, the alphabets/numbers/symbols will be scrolled in ascending order.



The character will be displayed here

This indicates font type whether upper case/lower case/number/symbol is selected. Use N/G to change from Upper case to lower case, vice versa and so on

Once the font type is selected, then for the first time press UP arrow to change the values.

5.3.1.3 Location (LoC) :-

On pressing the LoC, the display will show LoC-01

Using up and down arrows we can scroll and reach the particular location where we can edit the character.

The procedure of editing the values in same which is explained in section 5.3.1.2

5.3.1.4 Scroll Line 1 (SCLn1):-

When we press enter key from this step whatever we enter for footer line 1 from position FL1 will scroll from character-right to left and after a time delay it will come out to SCLn1.

5.3.2 Footer Line 2 (Ln2) :-

This is similar to section 5.3.1

5.3.3 Footer Line 3 (Ln3) :-

This is similar to section 5.3.1

5.4 Separation Line (SPL InE)

When ENTER key is pressed from SPL InE , the display will show 'LinE 1' Press Enter key, display will show LinE 1 1 - We can scroll between the options 1/2/3/4 using up and down arrow.

- 1- Dash
- 2- Asterisk
- 3- Hash
- 4- Underscore

This separation line 1 will be printed after header lines.

Similarly separation line 2 will be printed before the footer lines.

5.5 Copy (CoPy)

When ENTER key is pressed from CoPy , the display will show 'Copy 01'

This is related to no. of print copies. We can set from 01 to 09.

For example if 03 is entered here, then 3 copies of the receipt or label will be printed.

5.6 Auto Print (AuPr)

If auto print option is enabled, then when the weight is stable and printer is connected, the data will be printed automatically when the weight gets stable.

Ensure the transmission mode (section 4.1.6) in the communication settings is set for PRINT mode.

Y - Yes (Auto print enable)

5.7 Print Format (PFor):-

When ENTER key is pressed from PFor , the display will show 'For - 1'

Three print formats can be printed from this scale.

For -1 : Print Format 1

For -2 : Print Format 2

For -3 : Print Format 3

Print Format 1 (FOR - 1): Common for receipt paper and label paper

Header Line 1	
Header Line 2	
Header Line 3	

Sr. No.	: 1
Gross Wt	: 2.000 kg
Tare Wt	: 0.000 kg
Net Wt	: 2.000 kg
Count	: 0 PCS

Footer Line 1	
Footer Line 2	
Footer Line 3	

All the mentioned fields have Print Yes or No permission in the printer settings

Print Format 2 (FOR-2): Common for receipt paper and label paper

Header Line 1	
Header Line 2	
Header Line 3	

Sr. No.	: 1
Gross Weight	: 2.000 kg
Tare Weight	: 0.000 kg
Net Weight	: 2.000 kg
Count	: 0 PCS

Footer Line 1	
Footer Line 2	
Footer Line 3	

Print Format 3 (FOR-3): Only for receipt paper (Accumulation mode print)

Header Line 1	
Header Line 2	
Header Line 3	

Sr. No.	: 1
Weighment Details	
1)	2.000 kg
2)	2.050 kg
3)	1.900 kg
4)	1.985 kg
5)	2.000 kg
6)	2.000 kg
7)	2.015 kg
Total - 13.95 kg	

Footer Line 1	
Footer Line 2	
Footer Line 3	

Note: - Print format 3 is applicable only for the receipt paper either in 32 column or in 40 column thermal or in dot matrix printer. (we cannot use this format when we use it to print in label paper). This format will be printed only when the accumulation mode is ON (Section 2.9)

Use up & down arrow keys to scroll between the formats and select the desired format.

5.8 Printer Permissions (PrPrn):-

This option enables the user to give permission YES/NO for each field which can be printed which are mentioned in section 5.7 Use up & down arrow to scroll between the various fields and press enter key and then select y/n (Yes/No) option and once again press Enter key.

For example if FL2 (Footer Line 2) is not needed in the print, then you can keep n (No) in the print permission.

6 Factory settings (Fst)

During the Power ON, we have to press and hold the FUNC key for minimum 4 seconds, and the display will enter into the factory setting mode. Press Zero (Up) and Tare (Down) key to scroll between the different parameters in the factory settings.

The factory setting is password protected. When enter into the factory settings, display will show PASS. Enter the password 1918.

Then we have to press N/G Key (left shift) and enter 1918 using Zero Key (increment), Tare Key (decrement) and use N/G Key (to shift the previous entered to the left)

6.1 Scale Setting (SCSt)

6.1.1 Snr:-

This is for engineering purpose. Not applicable for the user.

6.1.2 Sdt :-

This is for engineering purpose. Not applicable for the user.

6.1.3 Pdt:-

This is for engineering purpose. Not applicable for the user.

6.1.4 rdt:-

This is for engineering purpose. Not applicable for the user.

6.1.5 Range (rng):-

6.1.5.1 SR-Single Range:-

If we select SR, then we can enter use the scale for one capacity.

6.1.5.2 DR-Dual Range:-

If we select DR, then we can enter use the scale for dual capacities. For example when we can use the scale up to 10 kg with 1 g as the division and above 10 kg to 20 kg, we can use the scale with 2 g as the division.

6.1.5.3 TR-Triple Range:-

If we select TR, then we can enter use the scale for triple capacities. For example when we can use the scale up to 10 kg with 1 g as the division and above 10 kg to 20 kg, we can use the scale with 2 g as the division and above 20 to 30 kg, we can use the scale with 5 g as the division.

6.1.6 Capacity :-

Here the scale allows the user to enter the full scale value. For example if we use the scale in single range and our desired scale capacity/full scale is 10 kg then we can enter 10000 here.

If triple range is selected for instance, then scale will ask us to enter Capacity 1, Capacity 2 and Capacity 3.

In this case Capacity 1 > Capacity 2 > Capacity 3

6.1.7 Division:-

The following are the division values available in the scale - 1, 2, 5, 10, 20, 50

6.1.8 Decimal Point (DP):-

In the setting we can select decimal point as per the scale capacity and division.

- **0(No Decimal Point)**
- **1(0.0)**
- **2(0.00)**
- **3(0.000)**
- **4(0.000)**

6.1.9 Unit (UNT)

This is scale default unit setting. We can make the scale either in kilogram or in gram or in litre.

- kg
- g
- l

6.2 Factory Calibration (FCAL)

After setting the range, capacity, division, decimal point and unit, we have press the M+ /MR Key when the display shows FCAL (Factory Calibration).

Then follow the following process.

- 1) The display shows ZCAL (zero calibration). We have to make sure there is no weight in the platform and then press the M+ /MR Key (enter). Now the display will show AD counts.
- 2) Once again press the M+ /MR Key. The display will show HLOAD and we have to place 50% of the full scale weight and then the display will show the corresponding AD count after pressing the Enter key.
- 3) Press the M+ /MR key again, the display will show FLOAD (full load). Keep 100% load (equal to full scale) and then press the M+ /MR Key. The display will show the corresponding AD count. Press the M+ /MR Key will show C.DONE (if not it will show C.FAIL) and the display will return to the home screen showing the actual weight.

6.3 Standard Calibration (SCAL)

After setting the range, capacity, division, decimal point and unit, we have press the M+ /MR Key when the display shows FCAL (Factory Calibration).

Then follow the following process.

- 1) The display shows ZCAL (zero calibration). We have to make sure there is no weight in the platform and then press the M+ /MR Key (enter). Now the display will show AD counts.
- 2) Once again press the M+ /MR Key. The display will show LOAD and we have to place weight above 20% of the full scale weight and then the display will show the corresponding AD count. Pressing the M+ /MR Key will show C.DONE (if not, it will show C.FAIL) and the display will return to the home screen showing the actual weight.

7 Error code

Error Code	Error Description
EPrErr	No EEPROM or EEPROM related problem
rSErr	The counts with respect to the set capacity and division is more than 16000
CntErr	ADC error. Place more weight (>20% of full scale)
CAPErr	Capacity not set

8 Modes

8.1 Simple Weighing

User should ensure the scale is showing the unit in kg or g and then they can use the scale. User can simply keep the weight on the pan.

If Printer is connected, press Enter button to print the receipt or label.

8.2 Simple Counting

To access the piece counting mode, press the Func/Esc key and the display will show 0 Pc initially. Keep the known quantity of pieces for the sampling. Once the pieces for sampling is kept on the pan, press Tare key. The display will toggle between the following values for sampling S-10, S-20, S-50, S-100, S-200, S-500.

Once the desired sampling value is reached (according to the pieces kept on the pan) is reached, press the Enter value and the display will start showing the no. of pieces and the user can now use the scale for the counting purpose.

Once the scale is OFF and ON, the display will come out of the counting mode and shows the actual weight.

Note : There is no memory for the sampling value

8.3 Accumulation

To use the accumulation mode, the accumulation mode should be either manual or in auto. Refer section 2.9.

When the accumulation mode is enabled, the summation symbol will be displayed. The user can keep the weight and press M+ button. The weight will be added to the accumulation memory and show the accumulated time (n X). If Auto is selected, once the weight is stable, the weight will be added to the accumulation memory.

To do the accumulation of the second weight, the first weight has to be removed and then the new weight should be kept and same procedure should be followed to accumulate the weights one by one.

The accumulation can be done till the weight reach 999999 in the display. After the display will show Overflow.

To view to accumulated weight and no. of times : Func + M+/MR - The display will show the no. of accumulated times first and then shows the accumulated weight till we release the Func + M+/MR Key.

To clear the accumulation memory : Func + zero in zero condition. Once accumulation memory is cleared, Cleard message will be displayed.

For accumulation print, refer section 5.7.

8.4 Litre Conversion

To use the scale in litre mode, go inside the factory settings and select the unit L (Litre) and come out of the factory settings.

Now the scale will work in the litre mode and show the litre values based on the litre conversion factor (refer section 2.6)



Designed, Developed & Manufactured By,
E. G. Kantawalla Private Limited

Next To Prakash Memorial School, Upper Kharadi Road, Ubale Nagar,
Wagholi, Pune-412207

Toll Free Numbers:

Sales - 1800 - 12 - EAGLE (32453)

Service -1860 - 12 - EAGLE (32453)

E-mail: sales@egkantawalla.com

website: www.egkantawalla.com

website: www.eaglescales.in