



# SETTING NEW TRENDS

Provider of Lifestyle and  
Industrial scales



“When a baby is born, the first step is weighing on a scale before being cradled in their mother’s arms.” — Essaji G. Kantawalla

**E.G. KANTAWALLA PVT. LTD.**

[www.eaglescales.in](http://www.eaglescales.in)  
[www.egkantawalla.com](http://www.egkantawalla.com)



# INDEX

|                               |    |
|-------------------------------|----|
| About us                      | 1  |
| Our story                     | 2  |
| Mission and vision            | 3  |
| Team eagle                    | 4  |
| Employee engagement           | 5  |
| Connecting with our customers | 6  |
| Our business                  | 8  |
| Our business partners         | 9  |
| <b>OUR PRODUCTS</b>           |    |
| Lifestyle and medical         | 11 |
| Retail                        | 12 |
| Industrial                    | 13 |
| Systems and solutions         | 14 |
| Crane scales                  | 15 |
| Industrial floor scale        | 16 |
| Weighbridges and axle pad     | 17 |
| Waterproof scales             | 18 |
| Aqua IP68                     | 19 |
| High speed check weigher      | 20 |
| Shipper check weigher         | 21 |
| Hopper weighing system        | 22 |
| Galaxy 103                    | 23 |
| CSR activities                | 24 |
| Testimonial                   | 25 |
| Our clients                   | 26 |

# About Us

- Three generations of prioritizing customers over profits at **EAGLE**.
- Originated with a visionary entrepreneur adapting to a changing world.
- Specializes in comprehensive weighing solutions, from simple measurements to intricate calibrations.
- **EAGLE** scales are sold and serviced in 24 countries, finding a new home every three seconds.
- Leaders in precision weighing, seamlessly integrating scales and systems worldwide.



## Reliable Organisation

The legacy which we have carried since our inception makes us, one of the most reliable organisation amongst all business sectors.



## Weighing range from 0.01 Mg to 120 Tons

Be it simple weighing, bulk weighing, dynamic weighing, weighing your new born baby or weighing a 120 ton fully loaded truck etc. Eagle is your one stop partner.



## Customer Relationships

Eagle has forged long-lasting relationships with its customers by not only distributing quality products but also by providing services for non eagle products.



# Our Story

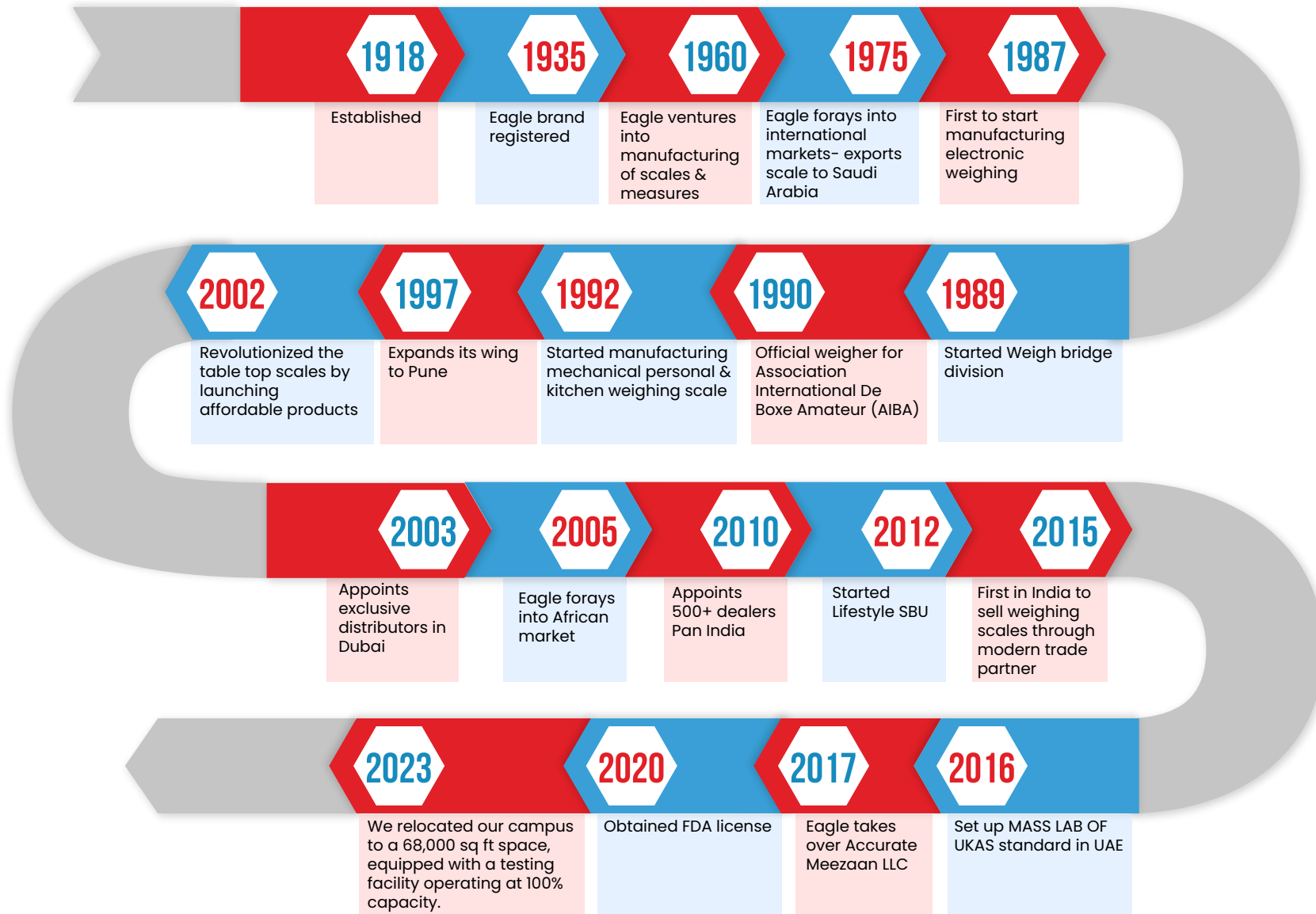

# Mission

To attain higher standards of Productivity, Quality, Profitability and Health pertaining to the facilitation of individuals and organizations associated with us.

## Core Values



### CUSTOMER

Customer Above All  
Deliver Best Or Nothing  
Everlasting Relationship



### ORGANIZATION

Merit Base Opportunity  
Responsibility With Passion  
Celebration



### TEAM

Respect people at large  
Excellence in service  
Committed to quality



# Vision

EAGLE endeavours to be a pioneer in the field of weighing, across all sectors by providing such unbeatable products and services which continually meet and exceed customer expectations. We firmly believe in fostering strong relationships with all those who associate with us i.e. from our Supportive Team to our Partners and our Customers and many others associated in our path-breaking journey with us.



## Team EAGLE

At EAGLE we believe that everyone is equal and must get the same opportunities.



Diverse team •  
Equal opportunities •

# Employee Engagement



Woman's day celebration

Trainings



Rewards & recognitions

Team Picnics



# Connecting with our Customers



Sales camps

Health camps



Dealer trainings

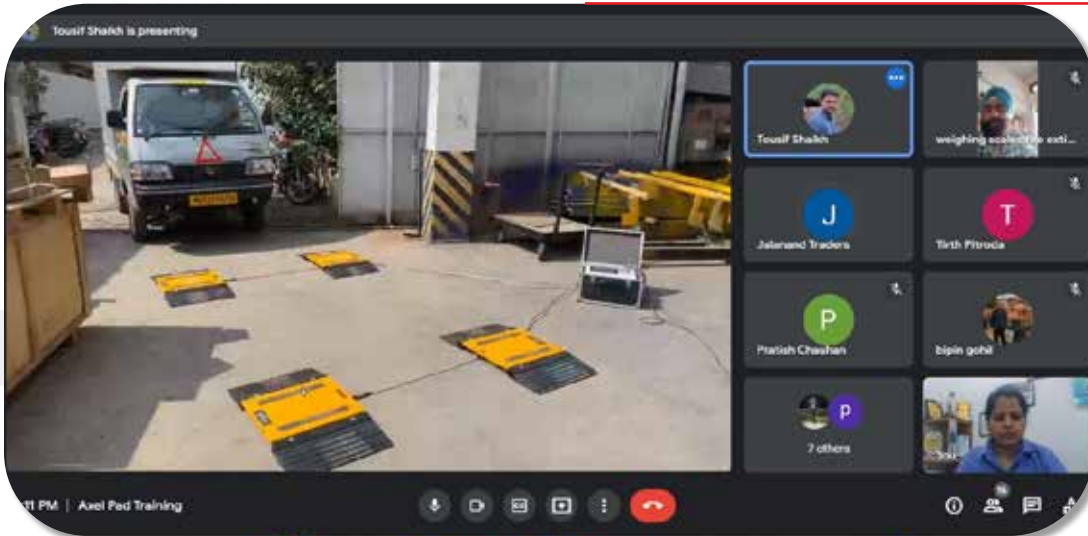



## Connecting with our Customers



Health camp for launch of a new hospital



African Exhibition

## Our Business

We have a total of **30,000** unique industrial & retail **customers**.

Our industrial & retail **products** are sold by **1,000 active dealers** across India, Middle East & Africa.

**300 active distributors** and **5,000 active retailers** for our lifestyle range of products.

Over 3,500,000 industrial scales sold.

Over 5,000,000 lifestyle scales sold.

Our current renews are ~ 8 million USD.

## Our Business Partners



Our products being sold through medical stores



Dealer meet

# OUR PRODUCTS ARE DESIGNED FOR ALL TYPES OF INDUSTRIES



# Lifestyle and Medical



## Personal Scale with Body fat

Analogue scale |  
Battery free scale |  
Body fat scale |  
Electronic scale | Smart weighing scale



## Luggage Scale

Travel light and hassle free with our compact luggage scale.

## Mother and Child

Electronic baby weighing scale equipped with high precision strain gauge sensors system.



## Height and Weigh Scale

Weight, Height, Body Fat, Voice Broadcast, Data Recording and Review



## Kitchen Scale

Electronic scale |  
Waterproof scale | Pet scale

\*Various other scales to suite your needs

# Retail



## Price Computing

Eagle Price Computing Scales are ideal for grocery, and other retail or food service weighing applications.

## Counting Scale

Weighing Cum Counting Indicator for heavy duty usage in indoor as well as outdoor environment.



## Table Top Titan

Suited for use in any part of India even in areas of extreme low voltage.



## Bench Scale

tFlexible, rugged bench scales for varied dry environment weighing tasks.

\*Various other scales to suite your needs

# Industrial



## Lab Balance and Precision Scales

The balance is draft-protected, ensuring stable, precise readings in standard conditions.

## Platform and Floor Scales

Platform and floor scales provide durable, accurate solutions for heavy-duty weighing.



## Waterproof Scales

Waterproof scale endures harsh conditions, allowing easy cleaning after use.



## Crane Scale

Crane scales, robust precision for lifting and accurately weighing heavy loads.

\*Various other scales to suite your needs

# Systems and Solutions

## High Speed Check System

High-speed Check Weighers ensure top accuracy, allowing increased line efficiency.



## Shipper Checkweigher

Ideal for Cartons, Boxes, and Bags. Capacity: 10-50 kg. Speed: 8-30/min.



## Hopper Weighing System

Hopper weighing system with load cells, junction box, and controller. Versatile for various batch processes.



\*Various other scales to suite your needs



## CRANE SCALE



### CRN Series – LDR/ LDF

CRN-LDR/LDF is IP65 Protected Rigid Aluminium Die Cast Construction Crane Scale, Anti-dust, splash proof and anti magnetic, Ideal for use in manufacturing setups, factories, Steel Industries and heavy duty industrial plants with alloy steel die pressed bow shackle.

360 rotating (\*LDF comes with a fixed hook) alloy steel die pressed lifting hook with safety latch. Equipped with infrared wireless remote control for simple user friendly operation and external battery charger and 2 sets of battery for 24 x 7 use.

### CRN Series – HDF

CRN – HDF is a solid steel construction for long term durability for heavy duty use with anti-dust , splashproof and anti magnetic, Ideal for use in Rough Industrial Environment on account of its solid steel structure.

Convenient and Safe to use. High Grade Alloy Steel Load cell ensures high accuracy. Equipped with infrared wireless remote control for simple user friendly operation and external battery charger and 2 sets of battery for 24x7 use.



# INDUSTRIAL FLOOR SCALES



## Floor Scale | Commercial & industrial weighing Scale | EIW Series

### Industrial floor scales

- These are design to use in commercial and industrial application where the customer can use the scale to weigh bulk materials and goods loaded on pallet trollies.
- Floor scales can be pit mounted as well.

### Industrial low-profile scales

- Available in two designs (fixed ramp or foldable ramps)
- Low profile scales are designed with deck height of less that 50mm which is more suitable for pallet trollies, hand carts and forklifts
- Some of our indicators have NTEP certification.

- EIW Floor scales designed for durability in commercial and industrial weighing
- Available in various sizes and capacities
- Features self-aligning, anti-slip feet for unidirectional load transmission
- Withstands tough industrial environments, handling overloading and shock loading
- Self-checking load cell assembly for accurate weighing
- Sturdy platform allows for easy relocation based on changing needs



# WEIGHBRIDGES AND AXLE PAD

## Pit Weighbridges

Modular weighbridges, high tensile steel construction, swift installation, resist bending under heavy loads, and durable in harsh environmental conditions.



## Pitless Weighbridges

Pitless weighbridge suits sites with challenging excavation, costly pit construction. Elevated structure allows vehicles from two directions with ramps provided.

## Axle Pad Weighing System

Axle Pad Weighing System measures wheel, axle, and total vehicle weight. Easily deployed on level surfaces, commonly used in various applications.



## Portable Weighbridges

Modular design ensures cost-effective transportation. Customers can choose prefab metal or concrete ramps. Easy shifting for surface mount weighbridges.

# Waterproof scales



Wash Down Table Top  
Weighing Scale | Aqua -  
IP68



Wash Down Bench  
Weighing Scale | Splash  
Bench - IP67



Wash Down Platform  
Weighing Scale | Splash  
Platform - IP67



Fully Waterproof Bench  
Weighing Scale | H2O  
Bench - IP69K



Fully Waterproof  
Platform Weighing Scale  
| H2O Platform - IP69K

# Wash Down Table Top Weighing Scale Aqua - IP68

AQUA is a convenient and reliable Waterproof Table Top Weighing Scale. Built with a stainless-steel housing that complies to IP68 waterproof design. This scale is totally waterproof, washable and easy is clean, making it a perfect choice for any environment where water and moisture are prevalent - meat packaging, poultry, fisheries etc. The super bright GREEN LED display ensures accuracy and easy visibility, even in dark settings, and its low profile makes loading and unloading objects faster and easier.



- Water/Dust/Wet Proof Design: IP68 stainless-steel body, washable, suitable for marine processing.
- Bright Display: Super Bright GREEN LED for clear weight visibility in low light.
- Compact Design: Lowered height (130mm) improves loading/unloading efficiency.
- Dual Power Sources: Rechargeable battery (DC6V, 4.5Ah) for 10-12 hours, AC power cord.
- Spirit Level Indicator: Ensures scale is level, critical for accuracy.



# Systems and Solutions

## High Speed Check Weigher

Our High Speed Check Weighers are with the utmost accuracy at top speeds and therefore permits extremely high throughputs leading to increasing line efficiency.

- More suitable for Food & Pharmaceutical Industry
- Capacity varies from 500 g to 10 kg
- Speed : Up to 150 pieces/min
- Accuracy : +/-0.2 mg to +/- 5 g according to the capacity

### Optional Accessories

- ✓ Metal Detector
- ✓ Bottle Separator
- ✓ 21 CFR Compliance



# Systems and Solutions

## Shipper Check Weigher

- ✓ More suitable for Cartons Boxes and Bags
- ✓ Capacity varies from 10 kg to 50 kg
- ✓ Speed: 8 boxes/bags per minute to 30 boxes/bags per minute
- ✓ Accuracy:  $\pm 0.1\%$  of F.S



# Systems and Solutions

## Hopper Weighing System

Hopper weighing system normally consists of load cells, junction box and weighing controller. It is widely used in process batch hoppers where batch can be of single or multiple materials depend on the application.

### Optional Accessories/Ports/Functions

- ✓ Flame proof Indicator
- ✓ 4 – 20 mA output
- ✓ Flame proof Junction Box
- ✓ 0 – 10 V output
- ✓ RS485 Modbus RTU output
- ✓ Feeding & Discharge outputs to control the inlet & outlet

- More suitable for Storage & Batch Hoppers
- Wide capacity ranges from 50 kg to 20 ton
- Accuracy :  $\pm 0.1\%$
- Stainless Steel & Alloy Steel Load cell
- Standard & Customise Mounting Kits
- Wall Mount & Panel Mount Type Indicators

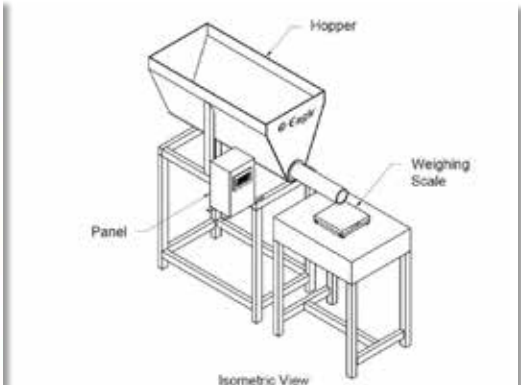



# Intelligent Terminal Galaxy103

Galaxy 103 Terminal is easy-to-use equipment with an easy menu which helps enhance production. The Galaxy 103 Terminal can be used everywhere. In modern industrial systems, instruments are required such that they optimally fulfil their intended purpose. If processes change, weighing equipment must also adapt. The Galaxy 103 Terminal has just that adaptability and offers the necessary flexibility. Galaxy 103 Terminal can be mounted on a table, on the wall or can be free standing on the floor.



- Data management
- Labelling and sticker printing
- software integration solutions



\*We undertake projects pan India

# CSR ACTIVITIES

The Venue



Donors Completing The Registration Process.



Testing Of The Donors In Progress.



Donors Awaiting Their Turn.

Donation In Progress – The Only Woman Donor.



Donation In Progress.



Recovery Of The Donors – All Seem Happy 😊



Thank You Sir! - All Donors Were Given A Certificate And A Small Memento On Behalf Of EAGLE.

# TESTIMONIAL



Plant : Sardar Vallabhbhai Road, Anand, Dist. Panchmahal, Gujarat  
Maharashtra (India) Ph : 02211-202301 E-mail : info@ovalmilk.com

Date: 25.07.15

**"To Whom So Ever It May Concern"**

"We are using 40 Ton Pin Less Weighbridge from eagle from over more than 5 years. We are satisfied with the product quality & after sales service from eagle. With their prompt after sales service, we have also entered for an AMC for weighbridge. We found eagle as a one stop solution for our weighing requirement. They communicate well & keeping us in the loop. We would have no hesitation in recommending eagle products to other prospective buyers"

For Oval Milk Products Pvt. Ltd.  
(Managing Director)



**SHITAL Metals Pvt. Ltd.**  
Reg. Office: Industrial Area, Phase-1, Road No. 12, PUNE - 411 006, Maharashtra (India) Ph. : 020-26687234

Gst No. 44. SASWAD-HIVARE ROAD, A/P HIVARE, TAL. PURANDHAR, DIST. PUNE 412301. TELEFAX : (02115) 222780  
EMAIL : amalsider@yahoo.co.in / info@shitalindustries.org  
WEBSITE : www.shitalindustries.org

AN ISO 9001:2008 Company

**Mfg. of Co, Pig Random & Layered Winding Welding Wire, Tin, Lead, Solder Alloy, Wire, Stick & Plate also Lead Free & Babbit alloy**

Date: 10<sup>th</sup> Sep, 2015

To,  
E.G. Kantawalla Pvt Ltd  
Sr. no 28/1 Damodar Nagar,  
Kharadi, Pune 411014

**Sub : Recommendation Letter**

You had supplied us Eagle Electronics Weighing Scale Model No- FL 110B2, in the year 2015-2016.

We really appreciate the quality of the product and service provided by E. G. Kantawalla Pvt Ltd.

We are happy to have you as one of our regular supplier and we are confident about your company will serve us long way.

Thank you and keep us the good work !!!

For SHITAL Metals Pvt. Ltd.

Director,  
Mr. Manoj Gujar



3<sup>rd</sup> Floor, G-6, Noble Manchester off Kharadi Police HQ, Pune - 411041  
Web: www.opencis.com | Product: www.bhajimandal.com | Phone: 020-6070 8188

Ref. No.: cisr/2015/03 Date: 11 July 2015

**Certificate of Recommendation**

To Whom SO Ever It May Concern

We have been using eagle product DM Series Table top scale for close to 1 year. The product and its features are really appreciable. The scale which we have bought of weighing vegetables is suitable for our application.

EAGLE's customer service is really good. We appreciate their constant support and will suggest eagle products to prospective buyers.

Best Regards,  
Director  
CIS Technologies Pune





ITW Delist, Global Fasteners  
4-26/1, Noida Industrial Park, Okhla Industrial Kanchnagar District-602105  
Tel: +9144 33546582 / Mobile: +91 8754462388

Dear Eagle team,

Thanks for the continuous support to us.

We had Purchased Eagle digital weighing scale (Capacity 3Kg max) on November 2013.

We are satisfied with quality, reliability and quick response.

Kind Regards  
*Karthikeyan natarajan (Quality Dept.)*  
ITW Delist, Global Fasteners  
Quality Executive  
Tel: +9144 33546582  
Mobile: +91 8754462388



|   |  |
|---|--|
| <p>VAZARI<br/>Regd. India Limited<br/>Maharashtra, India<br/>Ph: 020-26687234</p> | <p>CC-Digital - Domestic Page No. 1 of 1</p> |
| <p>To: E. G. KANTAWALLA PVT LTD<br/>KHARADI, PUNE NAGAR ROAD,<br/>PUNE-411014</p> | <p>Date Reference :</p>                      |
| <p>Attn :<br/>Tel No : Fax :<br/>E-mail : amn@egkantawalla.com</p>                |  |

Dear Sir/Madam,

I am writing this letter as a humble note of appreciation for the quality product and service provided by you. We are daily satisfied with your product and service. During last year we have received very good service after operation from your staff and especially from Mr. Sandeep Agarwal.

I appreciate the way you have trained your staff and the way they are following their duty perfectly. Keep up the good work. Once again thank you for the good service and I wish the company a lot of success.

Sincerely,

Thanks & Best Regards,  
Sandeep Pote  
Executive - SCM  
Vazari India Limited,  
Gst No:85, Survey No. 188  
High Cliff Industrial Estate  
Mansarovar, Pune - 412207  
Maharashtra, INDIA.  
Tel: +91-202-66215208  
Mobile: +91-8006900114  
E-mail: sandeep.pote@vazari.com  
Web site: http://www.vazari-group.com

# OUR CLIENTS

Government customers



GAIL (India) Limited



Key accounts customers



## OUR CLIENTS



When it comes to weighing, Eagle Scales is your one-stop partner!

## Contact



+91 951 196 2468  
1860 12 EAGLE (32453)



mt1@egkantawalla.com  
mt2@egkantawalla.com



E. G. Kantawalla Private Limited  
Next To Prakash Memorial School,  
Upper Kharadi Road, Ubale Nagar,  
Wagholi, Pune - 412207



**E.G. KANTAWALLA PVT. LTD.**

[www.eaglescales.in](http://www.eaglescales.in)  
[www.egkantawalla.com](http://www.egkantawalla.com)